

THIS DRAWING IS UNPUBLISHED. RELEASED FOR PUBLICATION, 19
 © COPYRIGHT 19 BY AMP INCORPORATED. ALL INTERNATIONAL RIGHTS RESERVED.

MOD	LOC	DIST	P	F	REVISIONS				
					ZONE	LTR	DESCRIPTION	DATE	APPD
-	GP	00				K	REV PER OUE0-0037-01	17OCT01	JR

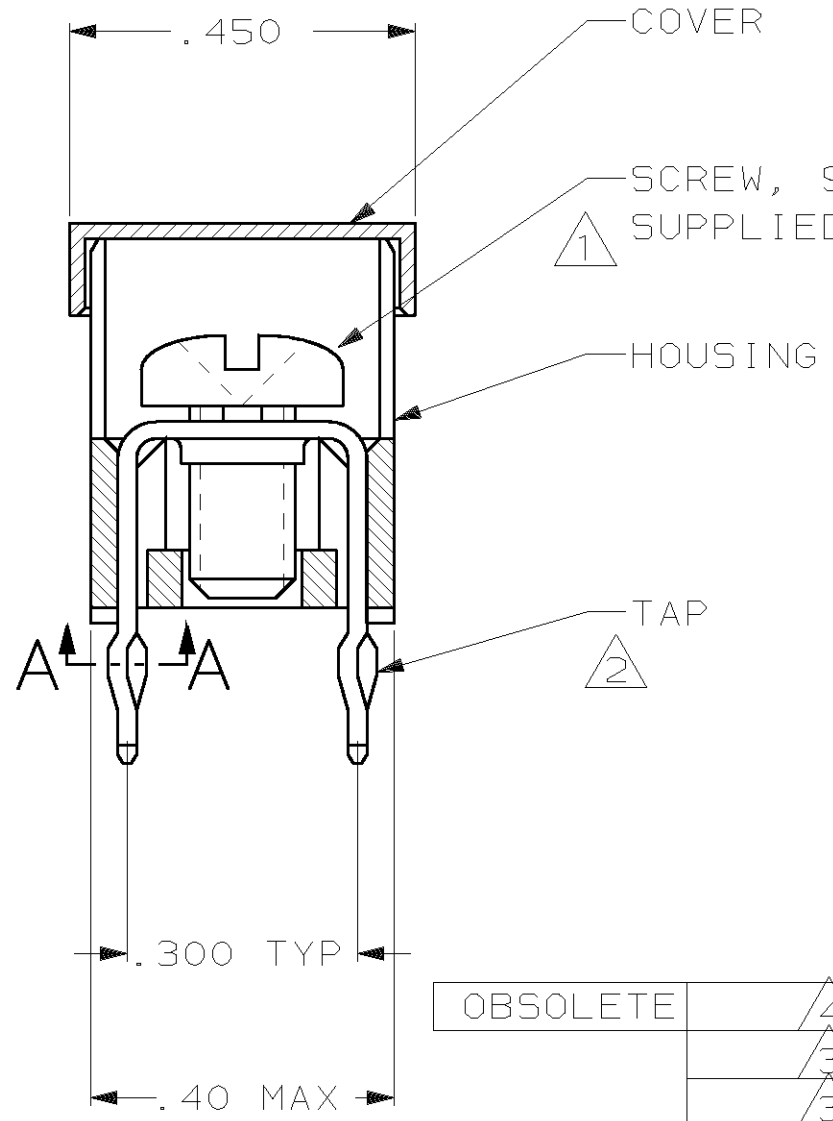
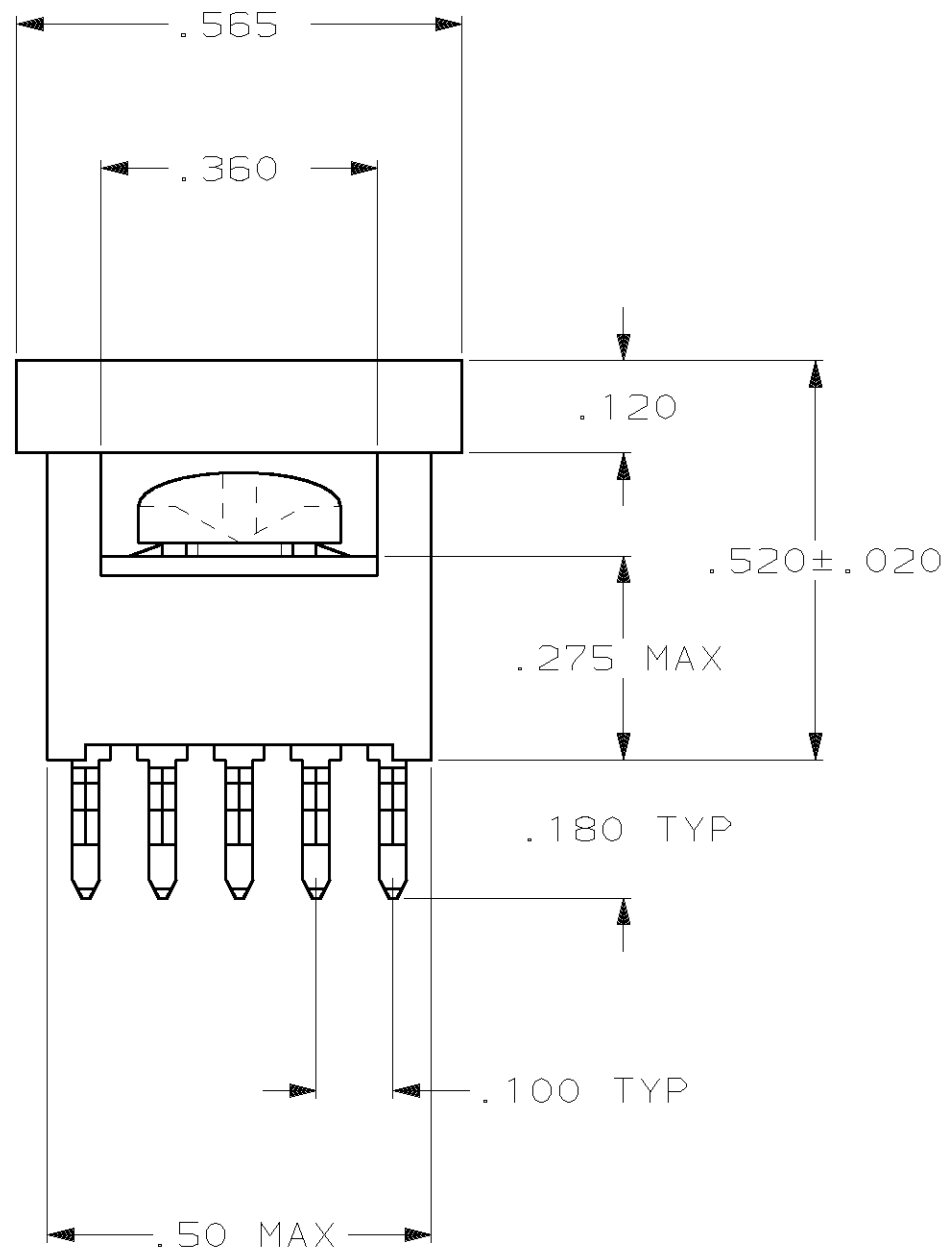

- ① TO PREVENT THREAD STRIPPING, SCREW TORQUE SHOULD NOT EXCEED 9 IN LBS.
- ② TAP HOLE IS 6-32UNC-2B, TWO MIN THREADS.
- ③ PACKAGED BULK.
- ④ PACKAGED INDIVIDUALLY.

OBSOLETE	④	YES	YES	55557-5
	③	YES	YES	55557-4
	③	YES	NO	55557-3
OBSOLETE	-	NO	YES	55557-2
	-	NO	NO	55557-1
	PACKAGING	HOUSING AND TAP ASSEMBLED	SCREW	PART NO

.050 ± .005 DIA

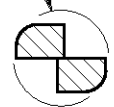

SECTION A-A
 SCALE 10:1
 10 PLACES

DO NOT SCALE PRINT. UNLESS SPECIFIED DIMENSIONS IN INCHES TOLERANCES ON:	DR J. McCLINTON 1/11/88
2 PLC DEC ±	CHK R. STONE 1/11/88
3 PLC DEC ± .010	APPD M. GALLOWAY 1/15/88
ANGLES ±	APPD M. GALLOWAY 1/15/88
MATERIAL HOUSING: NYLON TAP: COPPER ALLOY 725, .025 THICK	PRODUCT SPEC
FINISH TAP: .000150 TIN-LEAD OVER .000050 NICKEL	APPLICATION SPEC
	WEIGHT

AMP AMP INCORPORATED Harrisburg, Pa. 17105	
NAME TAP ASSEMBLY, POWER DISTRIBUTION	
SIZE B	FSCM NO 00779
SCALE 4:1	DRAWING NO 55557
	SHEET 1 OF 1

CUSTOMER DRAWING